

# Programming Hand-held Transmitter

## WARNING

To Prevent SERIOUS INJURY or DEATH:

- Keep Transmitter and battery out of reach of children.
- NEVER permit children to access the wall panel nor remote Transmitters.
- Operate the door ONLY when it is properly adjusted, and there are no obstructions present.
- ALWAYS keep a moving door in sight until completely closed. NEVER cross the path of a moving door.



To reduce risk of fire, explosion or electric shock:

- DO NOT short circuit, recharge, disassemble or heat the battery.
- Replace with 23AE 12 Volt batteries ONLY. Dispose of batteries properly.

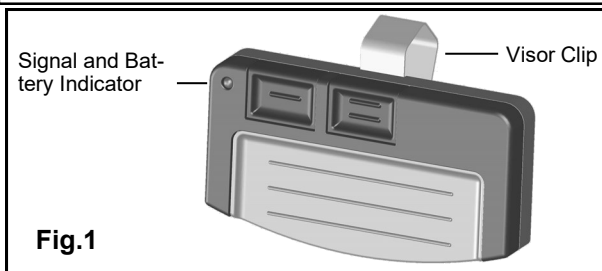

### To Program Transmitter(s):

1. Press/release the "LEARN" button on the rear control panel of the Opener. The courtesy light will illuminate with an audible click\*. The unit is now ready to accept a transmitter in the next 30 seconds as shown in Fig.1.
2. Press/release the large grey button on the Transmitter. **(Additional buttons used for multiple garage door openers)**
3. The courtesy light will flash twice indicating Transmitter has been stored successfully\*\*.

Up to 20 Transmitters (including wireless keypad codes) can be added to the unit by repeating the above procedures.

If more than 20 Transmitters are stored, the first stored Transmitter will be replaced. (i.e. the 21st Transmitter replaces the 1st stored Transmitter.)

\* If the courtesy light is already on, it will flash once and stay illuminated for 30 seconds.

\*\* If a Transmitter is not accepted, the courtesy light will stay on for 30 seconds, flash 4 times and then stay on for 2-1/2 minutes. Retry programming the Transmitter by repeating the steps above.

### Removing ALL Transmitters:

To remove ALL Transmitters from memory, press and hold the "LEARN" button for 5 seconds. The courtesy light will flash 7 times indicating ALL Transmitters have been removed from memory.

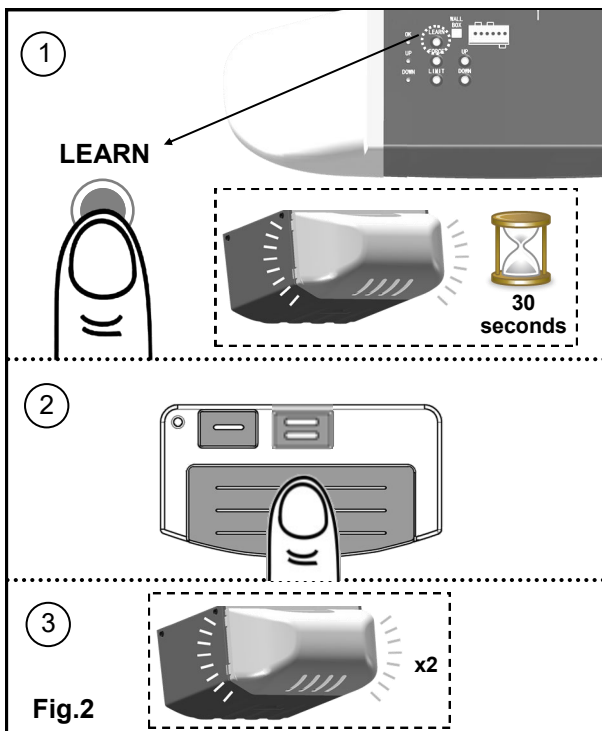

### Replacing Transmitter Battery:

When the battery of the hand held Transmitter is low, the indicator light will become dim and/or the range of the Transmitter will decrease. To replace the battery, remove the battery cover from the Transmitter as shown in Fig 3. Replace with a 23AE 12 volt alkaline battery with polarity shown in Fig.3.

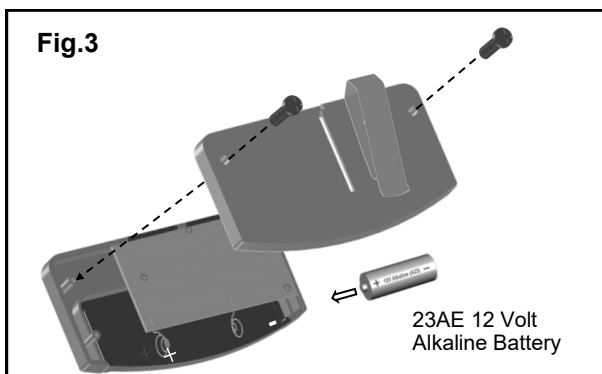

 **HomeLink®**  
compatible

### HomeLink® Compatible

This opener is compatible with HomeLink® in-vehicle systems. Consult your vehicles owner's manual for correct programming instructions. **NOTE:** For all other in-vehicle remote systems, contact the vehicle manufacturer for correct programming instructions.

This device complies FCC Rules for HOME OR OFFICE USE. Operation is subject to the following two conditions: (1) this device may not cause harmful interference, and (2) this device must accept any interference received, including interference that may cause undesired operation.